

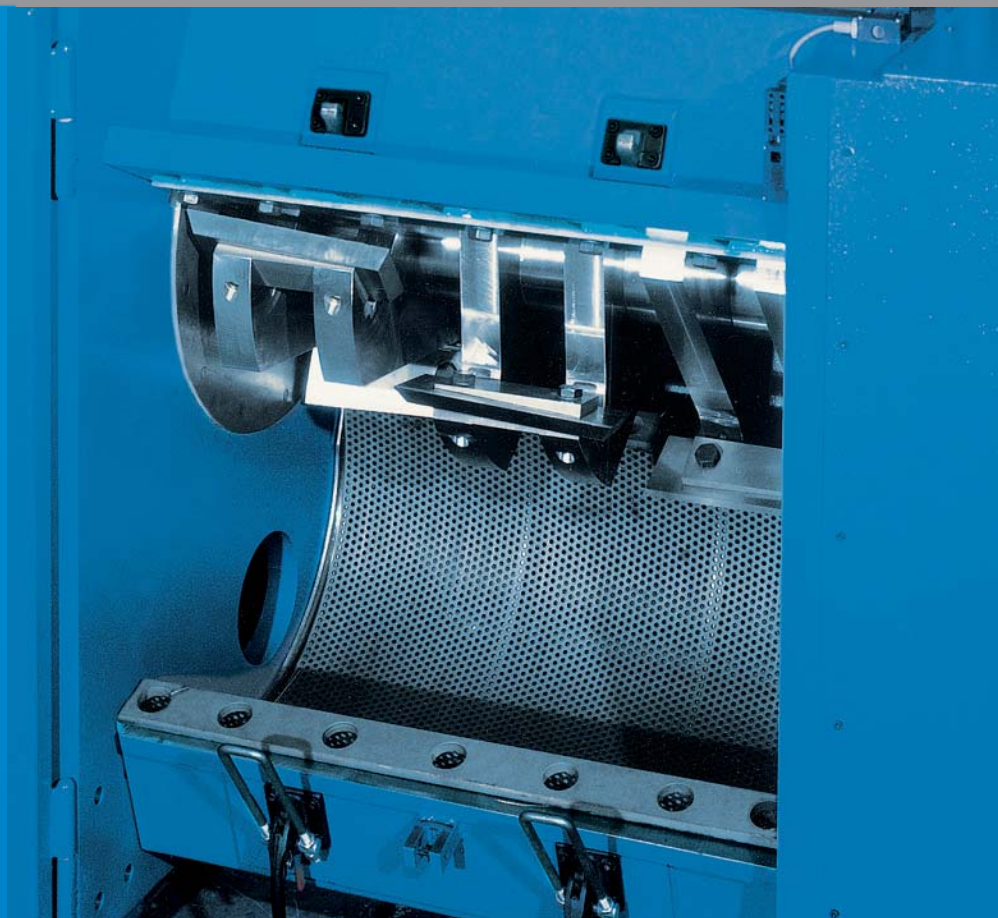

# Throughput of a thousand kilos and more GETECHA heavy-duty granulators

**RS 6000**  
by GETECHA

**RS 8000**  
by GETECHA



**GETECHA**

INDIVIDUALITÄT IST UNSER STANDARD

Choose the system partner who is also a competent dialogue partner: GETECHA.

For more than five decades, we have been acting as consultants to the plastics processing industry, developing, planning, and manufacturing consistently individual solutions from sprue recovery and automation systems to granulation. We have been supporting many of our customers for a very long time already. We simply feel at home with your challenges.

**Individualität ist unser Standard.**



## True greatness, tailor-made

The successful central granulator for all areas of plastic granulation. Unbeatable when it comes to granulation of large parts in the injection and blow-molding sector. Makes short work of scrap web rolls, extruded plates, bumpers, thick-walled pipes or extruder scrap.



### Designed for practical use

- Rugged, smooth-running, heavy-duty segmented rotor
- Rotor segments mounted on shaft with couplings, permits replacement of individual components
- Optimized airflow minimizes noise level and heat build-up
- Well-proven special rotors for various tasks



### Reliable productivity

- Solid belt pulley for additional centrifugal mass
- Continuous cutting circle guarantees consistently good granulate quality
- External rotor bearing with high safety factor
- Optical display of operational status



### Economical in use

- Hopper and suction tub open easily by means of hydraulic cylinders
- Minimal cleaning and maintenance time by virtue of pre-adjustable rotary blades
- Screen cradle can be rolled completely out of the machine
- Optimal machine accessibility

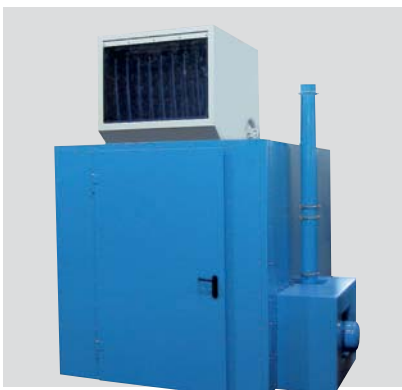

### Tailored to your production

- Modular design for individual adaptation
- Various rotor variants and wear-protection packages available
- Integrated noise protection
- Complete systems and accessories available
- Integration in existing systems possible

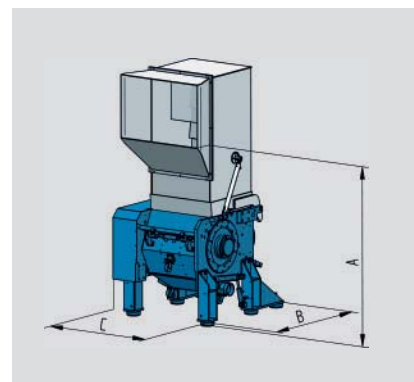

RS 6000	A	B	C
RS 6006	2.360 mm	1.900 mm	1.230 mm
RS 6009	2.360 mm	1.900 mm	1.530 mm
RS 6012	2.490 mm	1.900 mm	1.830 mm
RS 6015	2.490 mm	1.900 mm	2.130 mm

# Even more of everything, for everything

The biggest of the big. When tonnage is what counts, the RS 8000 is the granulator of choice. Equipped with an automatic feed system and granulate transport, it becomes a high-performance granulating center. A high level of the automation simplifies maintenance and ensures high economy.

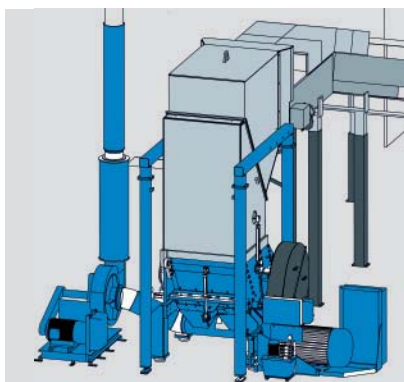

## ■ “Want to go a number higher?”

- Segmented frame rotor ensures optimal distribution of cutting forces, ideal intake behavior and a low noise-level
- Thick-walled stock outages and hollow shapes are seized flawlessly



## ■ Easy to clean

- Hopper and screen cradle open and close hydraulically at the press of a button
- Very good machine accessibility for cleaning and servicing
- Short rotary blades simplify handling when replacing blades



## ■ Reliable in operation

- Smooth drive motor start to avoid current peaks
- Solid belt pulley ensures even more traction
- Rotor bearings positioned outside of the grinding chamber
- Continuous cutting circle guarantees consistently good granulate quality



## ■ Individual features

- Special rotors for a very wide variety of granulation tasks
- Rugged but nevertheless flexible by virtue of modular design
- Complete systems and accessories available

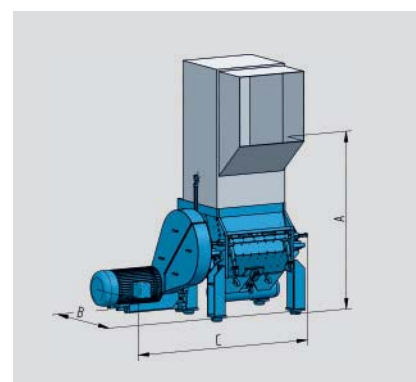

RS 8000	A	B	C
RS 8012	2.980 mm	2.075 mm	3.270 mm
RS 8015	3.150 mm	2.075 mm	3.570 mm



# Projects realized by GETECHA



## Granulation of blow-molded forms made of highly viscous and sticky plastic

### Requirements:

Granulation of fuel containers, flash and starting tubes made of COEX. The temperature of the material that is to be granulated exceeds 150 °C, i.e., the plastic is highly viscous and sticky. When designing the granulator, it is a matter of ensuring sufficient capacity in terms of throughput so that nothing sticks inside the grinding chamber. For storage, the granulate must be cooled to at least 80 °C in order to avoid melting together here, as well.

### Our solution:

A slow-running conveyor belt, equipped with a heat-resistant belt and a metal-detector tunnel, conveys the containers into the tall hopper of the RS 6012 granulator. An open three-blade rotor ensures that the containers are seized securely. Water cooling on the rear wall of the grinding chamber, ventilation of the hopper and a powerful evacuation blower prevent melting together of the plastic during the grinding process. The granulate is cooled via a cooling and de-dusting tower, checked for metal contamination, de-dusted and filled into a silo. Extensive safety technology, such as hopper monitoring, overload control and filling level controls, ensures trouble-free operation.

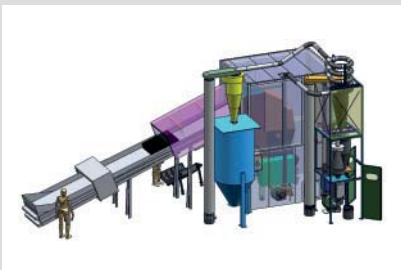

## Extrusion – Granulation of long pipes

### Requirements:

Granulation of PVC pipes with a length of up to 6,000 mm, wall thickness of 15 mm and diameter of 500 mm. Additionally, PP/PE pipes with a wall thickness of 10 mm and diameter of up to 300 mm are encountered. The granulator is set up in a basement room. The system is fed both from inside the basement by conveyor belt as well as via a bypass hopper with an opening on the production level. Plans call for filling the granulate into big bags on the production level.

### Our solution:

The 6000 mm-long pipes are fed via the bypass hopper to the RS 609 granulator, which is equipped with a 75 kW motor and an open, reinforced three-blade rotor. The hopper directly at the granulator is equipped with an opening for feeding by conveyor belt and a maintenance hatch. A powerful transport blower conveys the granulate to the big bag filling station on the production level.

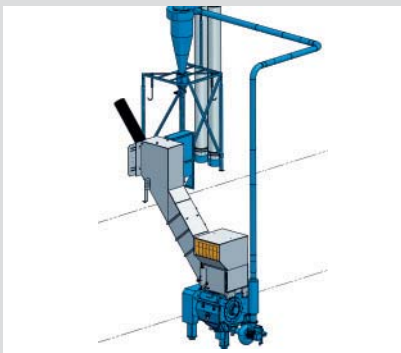

# Technical specifications:

Model	RS 6006	RS 6009	RS 6012	RS 6015
Rotor cutting diameter	600 mm	600 mm	600 mm	600 mm
Hopper opening	625 x 830 mm	925 x 830 mm	1.225 x 830 mm	1.525 x 830 mm
Cutting chamber opening	600 x 795 mm	900 x 795 mm	1.200 x 795 mm	1.500 x 795 mm
Cutting length	600 mm	900 mm	1.200 mm	1.500 mm
No. of rotary blades	3 x 2	3 x 3	3 x 4	3 x 5
No. of stationary blades	2	2	2	2
Type of cutting	scissors cut	scissors cut	scissors cut	scissors cut
Rotor revolution	400 rpm	400 rpm	400 rpm	400 rpm
Motor power, standard	45 kW	55 kW	75 kW	75 kW
Screen size, standard	8 mm, round	8 mm, round	8 mm, round	8 mm, round
Throughput	600 – 1.000 kg/h *	600 – 1.500 kg/h *	800 – 2.000 kg/h *	1.000 – 2.500 kg/h *
Electrical connection	3 x 400 V + N, 50 Hz	3 x 400 V + N, 50 Hz	3 x 400 V + N, 50 Hz	3 x 400 V + N, 50 Hz
Painting	RAL 7035, lightgrey RAL 5015, skyblue	RAL 7035, lightgrey RAL 5015, skyblue	RAL 7035, lightgrey RAL 5015, skyblue	RAL 7035, lightgrey RAL 5015, skyblue

Model	RS 8012	RS 8015		
Rotor cutting diameter	800 mm	800 mm		
Hopper opening	1.225 x 1.175 mm	1.525 x 1.175 mm		
Cutting chamber opening	1.200 x 950 mm	1.500 x 950 mm		
Cutting length	1.200 mm	1.500 mm		
No. of rotary blades	3 x 4	3 x 5		
No. of stationary blades	2	2		
Type of cutting	scissors cut	scissors cut		
Rotor revolution	400 rpm	400 rpm		
Motor power, standard	110 kW	110 kW		
Screen size, standard	8 mm, round	8 mm, round		
Throughput	1.000 – 2.500 kg/h *	1.500 – 3.000 kg/h *		
Electrical connection	3 x 400 V + N, 50 Hz	3 x 400 V + N, 50 Hz		
Painting	RAL 7035, lightgrey RAL 5015, skyblue	RAL 7035, lightgrey RAL 5015, skyblue		

\* depending on screen size and material



### **Granulation**

Beside-the-press granulators  
Central Granulators  
Heavy-Duty Granulators



### **Automation**

Sprue removal  
Handling systems  
Special automation solutions



### **Technical installations**

Development  
Manufacturing  
Start of operation

**GETECHA granulators** granulate plastics and return them to the production cycle. The granulators can be expanded into stand-alone recycling systems.

**GETECHA realizes** tailor-made, turnkey automation systems right around injection moulding machines. They are your one-stop source for development, manufacturing, service and training.

**GETECHA have** a worldwide sales and service network at their disposal. We guarantee fast, uncomplicated support.



### **GETECHA GmbH**

Am Gemeindegarten 13  
D-63741 Aschaffenburg  
Fon +49 (0) 60 21.84 00-0  
Fax +49 (0) 60 21.84 00-35  
E-Mail [info@getecha.de](mailto:info@getecha.de)  
[www.getecha.de](http://www.getecha.de)

### **GETECHA Inc.**

2914 Business One Drive  
Kalamazoo, MI 49048, USA  
Fon +1 269.373-8896  
Fax +1 269.344-7844  
E-Mail [sales@getechaUS.com](mailto:sales@getechaUS.com)  
[www.getechaUS.com](http://www.getechaUS.com)

GETECHA reserves the right to change the product specifications described in this data sheet and publish new data sheets accordingly at any time and without prior notice. GETECHA assumes no liability for the completeness and correctness of this information in terms of form and content. Illustrations may contain options.

# GETECHA

INDIVIDUALITÄT IST UNSER STANDARD